



UDC 81'366=111

Original scientific article

Received on 20.03. 2013

Accepted for publication on 30.10. 2013

Jasmina Hanić
University of Tuzla

The prefix *super-*: A cognitive linguistic approach

The aim of this paper is to shed more light on the semantic network of the prefix *super-* and to prove that what lends systematicity to the semantic structure of prefixes is that they are underlyingly not arbitrary but motivated. Cognitive linguistics offers many approaches helpful in explaining this phenomenon. Some of the mechanisms used for this paper are conceptual metaphor and metonymy.

Key words: prefix; trajector; landmark; spatial relations; concrete domains; abstract domains; metaphorical extensions.

1. Introduction

Langacker (1991: 16) claims that “grammatical morphemes, categories and constructions all take the form of symbolic units”. He also claims that affixes have semantic content which enables them to be categorised as any other lexical units. Bound morphemes do not behave differently from any other lexical unit and therefore should be analyzed as such. Having more than one meaning, words, i.e. lexical units in general including affixes, are considered polysemous. The central mechanism that connects the meanings is conceptual metaphor, defined as understanding one concept/conceptual domain (usually abstract) in terms of another concept/conceptual domain (usually concrete/physical). Therefore, various metaphoric and metonymic processes account for the polysemy of affixes and metaphor is regarded as the most important factor in semantic extension.

Key concepts in the analysis are trajector and landmark as every analysis of spatial relations in cognitive grammar is based on these concepts. According to Lan-



gacker (1987), every relational expression has a trajector and a landmark, which are defined as the entities between which the profiled relationship holds.

The *trajector* (TR) “is the entity construed as being located, evaluated, or described. Impressionistically, it can be characterized as the *primary focus* within the profiled relationship. Often some other participant is made prominent as a *secondary focus*. If that is the case, this is called a *landmark* (LM)” (Langacker, 2008:70). The trajector might move over a path that is called trajectory. Trajector and landmark are within the same domain. Domains can be concrete physical domains or abstract domains¹ like time, intensity, existence, emotions. Trajector and landmark are defined in terms of primary and secondary *focal prominence* which applies to both concrete (things) and abstract domains (relationships).

These constructs (TR and LM) enable us to distinguish pairs of expressions that are otherwise semantically identical, for example prepositions *above* and *below* (Langacker 1987). They seem to be semantically identical but the difference is indicated by the primary and secondary focus of the elements involved.

Langacker (1987: 156) also remarks that the basis of semantic extension is “some perception of similarity or association between the original (sanctioning) sense of an expression and its extended sense”. The extended sense is usually understood in terms of metaphorical relations: the understanding of an abstract domain is achieved by associating it to a more familiar, concrete domain. The concept of space very frequently functions as a source domain which is the case with the prefix *super-* discussed below.

Brugman (1981) was the first to offer a detailed semantic analysis of the English lexical item *over* using radial categories and schema transformations in order to prove that lexemes have their prototypical meanings and that non-prototypical meanings are directly or indirectly related to the central meaning, i.e. central member of a category.

Belaj (2004) gives a cognitive-based analysis of the verbal prefix *raz-* and its allomorphs in Croatian. Belaj (2008) contributes to cognitive linguistics in Croatian linguistics with his book *Jezik, prostor i konceptualizacija – shematična značenja hrvatskih glagolskih prefiksa*. The book provides a semantic analysis of eight Croatian spatial verbal prefixes. Klikovac (2004) provides a description of the semantic structure of the verbal prefix *raz-*. In her paper, Klikovac addresses the central issue of cognitive semantics which is categorization. She claims that every meaning

¹ Langacker (2008) introduces the term non-basic domain instead of abstract domain.



of *raz-* represents *a category of sub-meaning*. Some meanings are prototypical (confirmed by greater number of examples and more productive) while others are less typical and central (confirmed by smaller number of examples).

2. Discussion

The prefix *super-* is of Latin origin occurring originally in loanwords from Latin. In Latin it was used as an adverb and a preposition with the meaning ‘above, on the top (of), beyond, besides, in addition’. In Modern English it is used with the meaning ‘over and above, situated or placed above, on, or at the top of’, ‘more than, beyond’, ‘hierarchically superior’.

Most locative prefixes are polysemous, which is why SUPER- is both a locative and a prefix of degree and size. Its spatial reference can be seen in *superstructure* while in *supertanker* it means ‘superior’ and in *supercool* ‘exceeding a limit’, representing metaphorical extensions of spatial senses. SUPER- is not very productive due to the interaction of two important factors: first, SUPER is of foreign origin, secondly there is a far more productive native formative element, OVER, with similar meaning.

The general meaning of the prefix is presented by the superschema below (Figure 1) and the groups of words analyzed below are distinct elaborations of this schema. More prototypical are groups whose trajector and landmarks are concrete set in a physical space whereas the less prototypical are the groups involving abstract entities (TR and LM) located in an abstract domain, for example social hierarchy, intellectual activities, etc. Abstract meanings are extensions of concrete domains. For every meaning, there is a schematic representation provided. Concrete trajectors and landmarks are presented with a full line whereas abstract ones are presented with a dashed line.

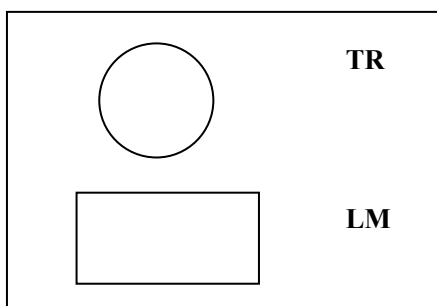

Figure 1. Superschema of the prefix *super-*.



2.1. Verbs

1. The first and the primary meaning of SUPER- is ‘over, above on the top, on, upon’ (OED), which means that a trajector is within a space area located above a landmark. However, this meaning is more common with adjectives and with verbs it involves the process of reaching this state by passing a trajectory from a lower position to a higher one. This movement is found in verbs like: *superedify*, *superimpose*, *superstruct*.

(1) *Upon which, in latter times, the Moors had **superstructed** a fortress.* (OED)

However, these verbs are more productive with abstract domains:

(2) *What small ground it hath as a foundation to **superstruct** any other doctrines upon.* (OED)

The schematic representation of this sense is an elaboration of the superschema given above and is presented by Figure 2 below. Dashed lines refer to the abstract nature of entities involved.

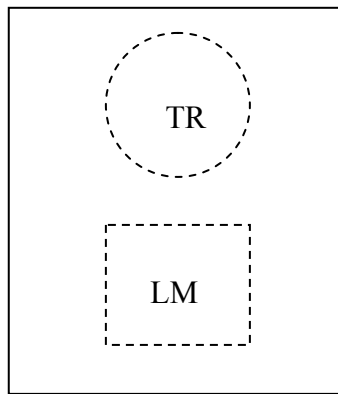

Figure 2. The sense ‘over, above on the top, on, upon.’

2. The sense of superiority and supremacy is a part of the semantic network of SUPER- as an elaboration of the superschema. SUPER- in the following verbs denotes entities (trajectors) of higher rank, occupying higher social positions with respect to the others (landmarks): *superbiate*, *supereminence*. Figure 1 above applies to this group as well.

3. The meaning of the verbs from this group is based on the sense ‘above’. To put or add something in addition to something else is conceptualized as putting it upon the same. With this sense, the prefix is used in the following verbs: *superadd*, *superimpregnate*, *superinfect*, *superinfuse*, *superlucrate*.



(3) *To a historical and a moral faith, God **super-infuses** true faith.*

(4) *Upon this there **supervened** that idea of royal power. (OED)*

Trajector in this case is not only positioned above the landmark but is in full contact with it which is presented in Figure 3 below:

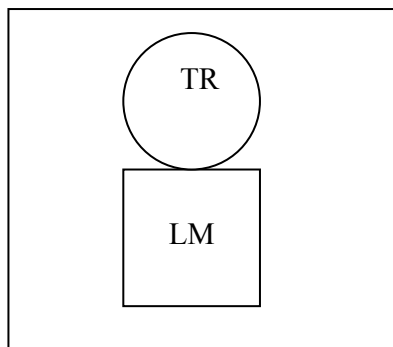

Figure 3. The sense ‘to put or add something in addition to something else.’

4. In the verbs *superexalt*, *superinduce*, *superinstitute*, *superordinate*, *superposit*, the prefix also expresses superiority as well as the movement of the trajector. Entities involved are human and the domain they are set in is abstract. Relations between entities are mapped from the spatial domain based on the motion schema involving a source (the initial state) and a target (the final or resultant state). As shown in Figure 4 below, trajector occupies a different position initially and moves over a certain path to reach a position that is figuratively above the one occupied by the landmark. Since the trajector moves by its own force it functions as agentive trajector at the same time.

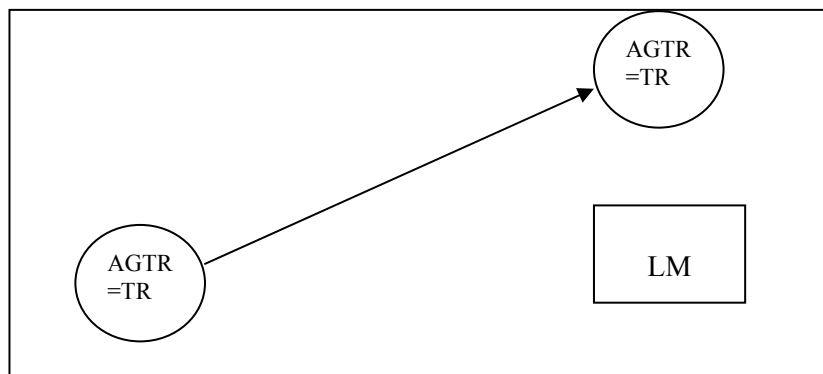

Figure 4. The sense ‘reaching a position higher than.’



5. The same motion and schema is found in verbs like *superdevil* ('to set the Devil over') or *supersatanize* ('to set Satan over'). In these verbs, we find metaphorical mappings of the spatial relations onto abstract domains. The verbs from this group have negative connotation, referring to one entity – trajector having power and control over another entity – landmark. This is achieved through the POWER/CONTROL IS UP metaphor.

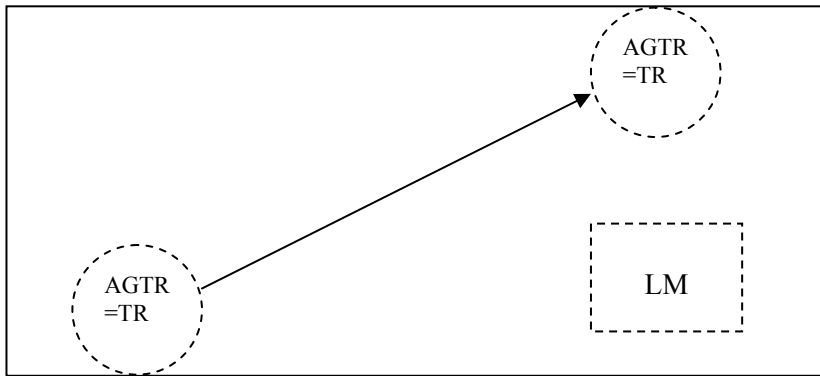

Figure 5. The sense 'reaching an abstract position higher than.'

6. *super-* also conveys the movement in the opposite direction, motion down from above but the position of the trajector is the same as in the previous group i.e. above the landmark. For the verbs *superfuse*, *superinfund* and *superseminate*, the trajector and landmark are concrete whereas for the verb *superact*, both trajector and landmark are abstract. This is presented by Figures 6 and 7 respectively.

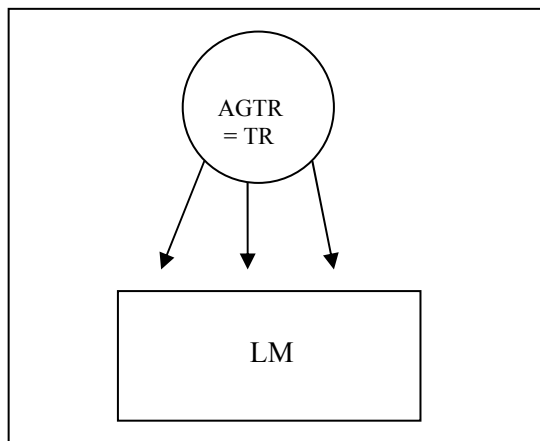

Figure 6. The sense 'moving down from above.'

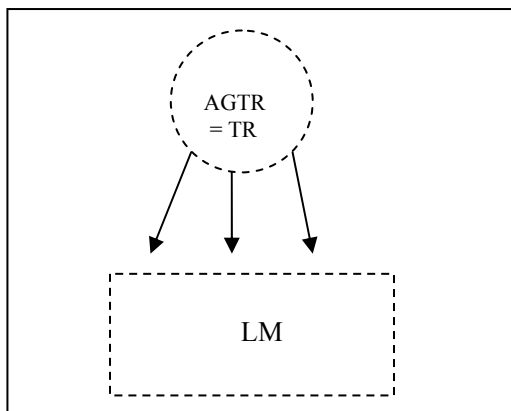

Figure 7. The sense 'moving down from above' within an abstract domain.

7. The following verbs represent a metaphorical extension of the previous group referring to social positions and sharing the meaning 'to look from above': *superinspect*, *superintend*, *supervide*, *supervise*, and *supervisit*. The trajector is above the landmark and the action expressed by the base is performed from a higher position. The last three verbs also imply the PART FOR WHOLE metonymy – a look for human conduct which is also the GOOD IS UP metaphor, specifically, BEING IN CONTROL IS BEING UP (Lakoff and Johnson 1980: 15). Look functions as a trajector that is (by an agentive trajector) directed down towards a landmark. The action expressed by the base is performed from a higher position. This is exemplified and illustrated below.

- (5) *The formation of local committees of vigilance to supervise the police.*
(OED)

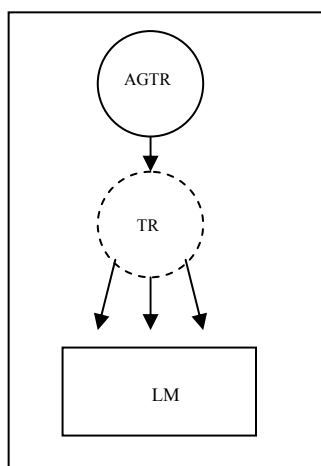

Figure 8. The sense 'to look from above.'



8. In the verb *superficialize*, *super-* denotes the sense of covering. Verbs *superindue* and *superinvest* fit into this group as they also imply the act of covering but with a piece of clothes.

9. Another physical sense of *super-* is ‘over the edge or brim’. It is found with only one verb *supergurgitate* which denotes a trajector in the form of liquid passing over the edge or a brim of a container as in overflow.

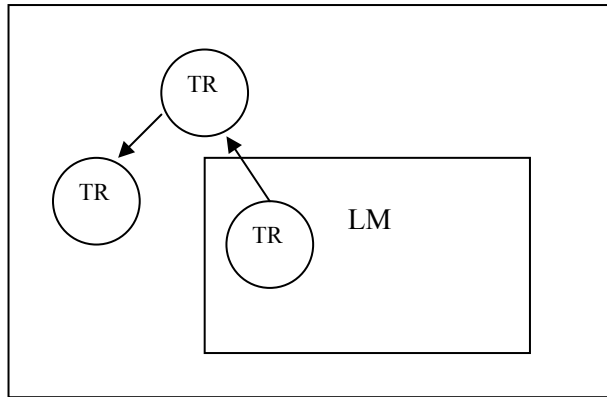

Figure 9. The sense ‘over the edge or brim.’

10. The prefix *super-* also conveys the sense of ‘excess’. Trajector is moving above and beyond the limit or a standard functioning as a landmark. This abstract motion is found with the following verbs: *superabound*, *supercharge*, *supercontract*, *supererogate*, *supercool*, *superexpend*, *superexpone*, *superfine*, *superheat*, *superonerate*, *superovulate*, *supersaturate*, *supersubtilize*. This is the most productive meaning of the prefix with verbs.

(6) *The English language superabounds with hissings.* (OED)

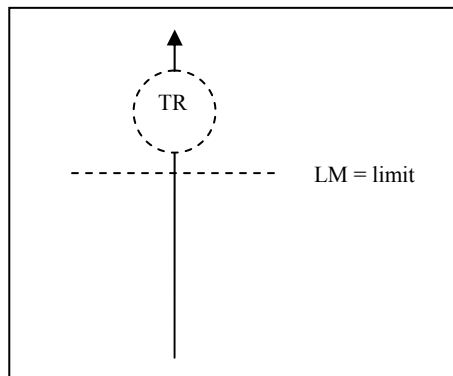

Figure 10. The sense of excess.



11. The sense of ‘excess’ is found in the domain of time, for example *superannuate*, *superlast*, *superlive* (outlive). This is achieved through the metaphor TIME IS SPACE where physical relations are mapped to the abstract concept of time. The prefix denotes that a trajector moves beyond a particular point in time which functions as a landmark. The new derivative conveys the sense ‘to last longer’. Figure 10 above applies to this group as well.

The primary reference of the prefix *super* - combined with verbs is to spatial prepositional relations. This sense is recognized in 6 groups of verbs from which other non-spatial meanings extend. The meaning verbs in the group 1 share is ‘above, upon’. This concept is mapped metaphorically to abstract domain of social relations to denote social superiority: groups 2, 4 and 5. The physical sense ascribed to the first group is the basis for the group number 3 ‘happening upon something else’. Some groups denote a downward movement of a trajector as in group 6. This spatial reference serves as a basis for metaphorical (and metonymical) extension in group 7 – ‘look from above’: Groups 8 and 9 convey express physical relations: the sense of ‘covering’ and movement ‘over the edge or brim’ respectively. Groups 10 and 11 share the aspect of ‘excess’.

2.2. Nouns

1. With nouns, *super-* also functions primarily as a locative prefix with the meaning ‘above, on the top’, e.g. *superaltar*, *superstratum*, *superstructure*. Both trajector and landmark are concrete and located in physical space. The schematic representation for this group is the same as superschema (Figure 1 above). Nouns like *superimposition* and *superposition* primarily refer to physical objects but also to abstract domains as in the examples that follow:

- (7) *The superimposition of the utilitarian civilisation of the West on the Indian civilisations.* (OED)
- (8) *At its mathematically most basic, superposition is just the adding together of quantities of different sorts.* (BNC)

2. In the following nouns, *super-* expresses a higher social position: *superordinancer*, *superordinate*, *superordination*. This group represents an extension of the meaning number 1: physical relations are mapped onto abstract domain of superiority. This is achieved through the conceptual metaphor MORE FAVOURABLE SOCIAL POSITION IS UP (LESS FAVOURABLE SOCIAL POSITION IS DOWN). The abstract domain of social sphere is conceptualized on a vertical axis in such a way that powerful entities are up and the ones without power are down. This gives rise to another meta-



phor SUPERIOR IS UP. Entities involved are human and the trajector is occupying a socially higher position than the landmark. Figure 2 above applies here as well.

3. With the sense ‘above’, *super-* is also used to refer to abstract concepts and abstract entities. The following verbs have the meaning ‘above, beyond this world’, above the range, scope, capacity’ of what is denoted by the base: *supercelestial* (*n*), *superessence*, *supermundanity*, *supernaturaldom*, *supernaturalism*, *supernaturalist*. SUPER- implies that trajector passes above and beyond an abstract boundary setting the limits or the scope of an abstract concept. This group also represents an elaboration of the general meaning of the prefix presented by superschema.

4. In nouns *supersign* and *super-writing*, *super-* retains its core meaning ‘above’. The difference is that both trajector and landmark are concrete, two-dimensional pieces of writing and the prefix denotes that the trajector is above the landmark, which is also a piece of writing.

5. The sense ‘upon, in addition’ conveyed by the prefix in the following nouns is also based on the superschema and related to group 1: *supercharge* (also ‘excess’), *superimpregnation*, *supersemination*. *super-* implies that a trajector is positioned above another entity usually of the same kind that functions as landmark. ‘Besides, in addition, extra’ is the sense found with the following nouns as well: *superaddition*, *superinfusion*, *superlucration*, etc. They are marginal members of this group and the following since they can be used to refer to further addition of either physical or abstract entities as shown by the example below. The schematic representation is Figure 2 above.

(9) *With all these powers, in **superaddition** to his own character.* (OED)

6. Extension of the previous sense is found with nouns like *superfeudation*, *superinstallation*, *superinstitution*, etc. in which *super-* means ‘upon something of the same kind, secondary’: The metaphor ACTIONS ARE PHYSICAL OBJECTS allows us to conceptualize more abstract, metaphorical scenarios exemplified below.

(10) *If a second institution is granted to the same church, this is a **superinstitution**.* (OED)

7. Another physical sense of *super-* is coming down from above, e.g. *superaffusion*, *superfusion*. Trajector moves downward to reach the surface of the landmark as presented in Figure 4 above.

8. The prefix *super-* in this group of nouns denotes ‘supervision’: *superintendent*, *superintender*, *superintendentship*, *superinspection*, *supervisor*, *supervisorship*, *supervisory*, *supervisure*. This is once again a metaphorical extension



achieved through the MORE IS UP metaphor. What is coming down from above is a look which is the PART FOR WHOLE metonymy – a look for human conduct. Figure 8 given above also applies to this group.

9. The sense of ‘excess’ implies that a trajector goes above and beyond a certain amount functioning as a preset limit. *Super* - in the following verbs conveys the sense ‘exceedingly, extremely, supremely’: *superabundance, superacidity, superarrogancy, supereminency, superheat, supernormality, supersaturation, supersensibility, supersensitivity, supersubtlety, etc.* In other words, trajector surpasses what is considered a norm or a limit which functions as an abstract landmark.

10. In this group, *super* - denotes people possessing qualities that surpass qualities of other people: *super-giant, superman, supermind, superpower, superstar, and superwoman*. As a result human trajectors are considered superior to landmarks who are in this case ‘ordinary’ humans referred to by the base.

The same schema is applied to physical objects, things: *super-alloy, super-bike, superbomb, superfluid, supergene, super-highway, superjet, supermarket, super-molecule, superrat, superstore*. A concrete trajector passes over a path reaching a target position that is better and more desirable than a lower position (the BETTER IS UP metaphor). *Super* - denotes greatness that is above the standard, surpassing these standards as well as other entities of the same kind.

- (11) *Later, the star evolved into a blue **super-giant**, just a few thousand years before the explosion.* (BNC)
- (12) *In such a reaction the energy would be released at an explosive rate which might be described as a ‘**super bomb**’.* (OED)

There are also abstract concepts like, for example, *super-ego* in which *super-* denotes an abstract entity that controls another entity. Conceptual metaphors CONTROL IS UP and LACK OF CONTROL IS DOWN underlie this concept. This can be seen from the example below:

- (13) *When the moral **superego** takes charge and the ego is no longer coercive but submissive.* (OED)

11. The sense of ‘excess’ manifests itself in the temporal domain with the following nouns: *supervivant, supervency, survivor*. The concept of time is conceptualized in terms of spatial relations. A LINEAR ORDER schema is used for understanding time where events are conceptualized as coming one after another in a linear order. Through the TIME IS MOTION metaphor, future times are conceptualized as being in front and past times as being behind. In other words, time is conceptual-



ized as a horizontal line. However, the meaning of the prefix in this group is based on the verticality schema where events happening at an earlier stage are conceptualized as being up and the ones happening after (later) are down. The prefix *SUPER-* denotes that a trajector moves beyond a point in time, i.e. lasts longer. The noun *survivor* implies that the human trajector corresponding to agentive trajector moves through time. This is based on the metaphor *TIME PASSING IS MOTION OF AN OBJECT*.

12. Vertically higher position is found in the domain of sound. In nouns *supersound* and *superoctave*, *super-* conveys the figurative sense 'above, high in sound'. In this group as in the previous one, trajector passes an abstract boundary functioning as a landmark..

What both word classes combined with *super-* have in common is that their primary reference is to spatial, prepositional relations, i.e. one entity physically positioned above another. For both word classes, this concept is mapped metaphorically to the abstract domain of social relations to denote social superiority. Another physical sense is the motion of one entity upward to reach a position above another entity. This is also extended to abstract domains, e.g. 'surpassing a limit or an accepted standard'. The prefix is used to express 'excess' in different domains (quality, intensity, time, sound). The comparison of the semantics of *super-* with different word classes is given in tables below (for spatial and abstract senses respectively).

Table 1. The semantic network of the prefix *super-* combined with different word classes – spatial senses.

meaning	Word class	
	verbs	nouns
'above'	√	√
'upon something of the same kind, secondary'	√	√
'above a piece of writing'		√
'project over another entity'	√	
'motion down from above'	√	√
'covering'	√	
'over the edge or brim'	√	



Table 2. The semantic network of the prefix *super-* combined with different word classes – abstract senses.

meaning	Word class	
	verbs	nouns
'superior position, rank'	√	√
'above, beyond this world'		√
'upon something of the same kind, secondary'	√	√
'look from above, supervision'	√	√
'excess, to exceed the limit'	√	√
'superiority in quality'		√
'excess in time'	√	√
'high sound'		√

3. Conclusion

The analysis has been conducted in order to establish the semantic structure of the meanings of the English prefix *super-* classed as a prefix of degree and size. It can be concluded from the analysis that the prefix *super-* with primary spatial meaning can be described in terms of trajectors and landmarks with a single schematic feature functioning as superschema which is present in and central to the meanings of all the words formed with the same prefix.

The semantics of the prefix is interesting because of its polysemous character. All senses of the prefix analyzed can be understood as members of a category and one sense is considered central unifying all other senses. The non-central senses cannot be predicted from the central senses but are not arbitrary. They are conceptually related through metaphoric and metonymic links. A significant role in these transformations and extensions plays cognitive space because through spatial structuring we conceptualize other domains of human experience like time, existence, emotions, intellectual activities, etc. These abstract domains are given certain spatial frame with the aim to explain their meaning.

References

- Belaj, Branimir (2008). *Jezik, prostor i konceptualizacija – shematična značenja hrvatskih glagolskih prefiksa*. Osijek: Sveučilište Josipa Jurja Strossmayera.
- British National Corpus. <http://sara.natcorp.ox.ac.uk>.



- Brugman, Claudia (1981). *The Story of Over*. MA Thesis, University of California, Berkeley.
- Klikovac, Duška (2004). *Metafore u mišljenju i jeziku*. Beograd: Biblioteka XX vek.
- Lakoff, George, Mark Johnson (1980). *Metaphors We Live By*. Chicago and London: The University of Chicago Press.
- Langacker, Ronald W. (1987). *Foundations of Cognitive Grammar, Vol. 1: Theoretical Prerequisites*, Stanford: Stanford University Press
- Langacker, Ronald W. (2008). *Cognitive Grammar: A Basic Introduction*. Oxford and New York: Oxford University Press.
- Oxford English Dictionary (on CD-ROM), 2nd edition (1992). Oxford: Oxford University Press.

Author's address:

Faculty of Philosophy
University of Tuzla
Tihomila Markovića 1
75000 Tuzla, Bosnia and Herzegovina
jasmina.hanic@untz.ba

PREFIKS SUPER-: KOGNITIVNO-LINGVISTIČKI PRISTUP

Cilj je ovoga rada dati prikaz semantičke strukture prefiksa SUPER- i pokazati da je ono što daje sustavnost semantičkoj strukturi spomenutoga prefiksa činjenica da su njegova značenja motivirana. Kognitivna lingvistika nudi mnoštvo pristupa pomoću kojih se može objasniti taj fenomen. Neki od mehanizama korištenih u ovom radu jesu konceptualna metafora i metonimija.

Ključne riječi: prefiks; trajektor; orijentir; prostorni odnosi; konkretne domene; apstraktne domene; metaforička proširenja.